

An analytical method to compute an approximate value of the site percolation threshold p_c

A. Rosowsky^a

CEA, DSM/DAPNIA/Service de Physique des Particules, CE-Saclay, 91191 Gif-sur-Yvette Cedex, France

Received 27 July 1999 and Received in final form 29 November 1999

Abstract. An analytical method to compute the site percolation threshold is introduced. This method yields an approximate value of p_c larger or equal to the real value. As examples, the computation of p_c is presented for 4 lattices in 2 dimensions: square, triangular, honeycomb and kagome. The results obtained are 0.592 871 6, 0.5, 0.765 069, 0.654 653 7, to be compared with the real values 0.592 746 0, 0.5, 0.697 043, 0.652 703 6. The method is not limited to 2 dimensions.

PACS. 05.70.Fh Phase transitions: general studies – 64.60.Ak Renormalization-group, fractal, and percolation studies of phase transitions – 64.60.Fr Equilibrium properties near critical points, critical exponents

1 Introduction

Site percolation is a simple mathematical model which is used to study and illustrate continuous phase transitions [4–7, 15, 27, 33, 34, 36]. It has also been used in computer models to simulate nonlinear propagation [2, 39, 41] in fields as diverse as the epidemic spread of diseases [35], liquid migration in porous media [45] or the propagation of forest fire [1].

Site percolation is a phase transition for which scaling laws are known. The value of the percolation threshold p_c can be computed by Monte Carlo techniques which use extrapolations from finite size lattices [8–11, 13, 14, 17, 21, 28, 31, 32, 37, 38, 43]. Except for a few specific cases, the value of p_c is estimated with Monte Carlo simulations.

As opposed to this, the method presented in this paper is analytical and based on a physical interpretation of the local structure of clusters at $p = p_c$.

General formulas to compute an approximate value of p_c have been proposed [18, 19, 22–26, 30, 44]. These formulas are postulated and do not give an insight into the percolation phenomena. They are useful for lattices embedded in a space whose dimension is larger than two and where Monte Carlo techniques require too much computing time. The precision of these formulas is not competitive with Monte Carlo techniques in two dimensions where precise estimations are possible with current computers.

A computer with a specialized architecture [46–48] was also built to study conducting properties of networks at the percolation threshold.

At threshold, an infinite cluster has a fractal structure and the divergence of geometric quantities [29, 40, 49] like the cluster perimeter, or the number of sites in the cluster leads to power laws. The powers in these power laws, called critical exponents, take the same values for several lattices which are then grouped into universality classes of percolation: each class is defined by the set of critical exponents. The critical exponents are computed by renormalization group techniques. These exponents are related by simple arithmetical relations. However, the threshold value $p = p_c$ is not universal but specific to each lattice geometry.

The interpretation of the local structure is given in Section 2 together with an intuitive presentation of the method. A formal definition of the objects used in the method is given in Section 3. The method is illustrated in Section 4 by the computation of p_c for four lattices in two dimensions: square, triangular, honeycomb and kagome. The method is not limited to two dimensions.

The method presented in this article is for site percolation and “percolation” will refer to “site percolation” in the following.

The method presented here relies on the preferred directions of cluster formation on the lattice. It gives a different value of p_c for each family of equivalent directions. When the geometry of the lattice is such that there is only one family of preferred directions, like in the triangular case, the method gives the exact value of p_c . The method is based on the physical interpretation of the percolation phenomena but no mathematical proof of its validity is presented: mathematically, it shall be considered a conjecture supported by the results obtained for four different lattices in two dimensions.

^a e-mail: andre.rosowsky@cern.ch

Furthermore, no mathematical relation has yet been established to link the values of p_c yielded by different preferred directions to the real value of p_c . The fact that the real value of p_c is recovered when there is only one family of preferred directions is a conjecture.

2 The local sensitivity of the clusters to the addition-removal of points at p_c

Let's consider a finite lattice of size $N \times N^1$. Starting from no occupied site, let's change the status of sites randomly, from empty to occupied and one at a time. The occupied neighbouring sites are grouped to form clusters. We define a walker as being an automaton whose goal is to cross the whole lattice, in a prescribed direction, by hopping from one occupied site to a neighbouring occupied site. The random change of status of a site from empty to occupied, increases the size of the clusters. At each step, a new walker is started to try all the possible paths. As soon as the walker can cross the lattice the process is stopped. The full process from the situation with no occupied site, to the first occurrence of a connecting path for the walker to cross the whole lattice is called a run.

The local configuration around the last point added in a run plays a special role in the process: removing this point cuts the cluster in two disconnected clusters. Such a site is called a "pivotal" site for a left-right (or top-down) connection.

When repeating the experiment several times, the distribution of the fraction of occupied sites at the end of each run is built. The peak of this distribution defines the function $p_c(N)$. The percolation threshold p_c is the limit of $p_c(N)$ for N infinite. The existence of a crossing path through the lattice is determined by the last site status which is changed: the crossing path at threshold is locally 1 site dependent in a prescribed direction.

Our conjecture is the following: the local configurations of occupied sites, where the change of status of a single site cuts the cluster in two disconnected clusters, have a maximum probability at $p = p_c$.

The method derived from this observation is a three steps process.

- Given a fixed site called the central site, list all the local configurations of occupied/empty neighbours such that the change to empty status of the central site would prevent the walker from crossing the configuration.
- Compute the probability function associated to this set of configurations. This function is polynomial with p as single variable and is noted $R(p)$.
- The maximum of $R(p)$ in the interval $]0, 1[$ is the approximate value of p_c , it is computed by finding the root of $R'(p)$ between 0 and 1.

The method relies on a subset of configurations centered on pivotal sites. These configurations are related to the axes of symmetry of the lattice.

¹ in two dimensions. In d dimensions the size would be N^d .

The algorithm computes the probability of a crossing in a prescribed direction (later called the principal direction) across a finite block (later called the 1ST). Thus in-principle large-volume computation is replaced by finite-block computation.

3 Definitions and computation steps

The steps which were only loosely described above are formally introduced in this section by defining:

- the principal directions and the 1-site sensitive tile;
- the entry and exit sites;
- the paths and the configurations.

The method presented here is not limited to lattices in two dimensions and the following definitions are not dimension dependent.

3.1 Definition of the "principal directions" and the "1-site sensitive tile"

In all the following, one site has been chosen in the lattice. This site which is singled out is called the central site.

The local sensitivity to the status of a single site at $p = p_c$ is not spatially isotropic. Given the symmetries of the lattice, the minimal number of sites along a path that joins two consecutive sites in a given direction changes with the direction. For instance, in the square lattice, starting from the central site and considering one of its nearest neighbours along a vertical direction, the path joining these two sites has only two sites: themselves. If we consider one of the diagonal nearest neighbours, the path joining this site to the central site is made of one horizontal and one vertical step and it passes through another site, in total three sites.

Therefore the local configurations and the percolation directions are related. To take into account both aspects, locality and directionality, each direction of interest imposed by the lattice symmetry is associated to a small finite set of sites, containing the central site, called a tile. The status of the central site decides whether or not a walker can cross the tile along the associated direction. This direction is called the principal direction and it is an axis of symmetry of the lattice. The tile is called the 1-site sensitive tile, or 1ST.

The 1-site sensitive tile contains the central site and at least two other sites in the lattice: one on each side of the central site and both on the principal direction. The two sites of the 1ST, farthest from the central site, and located on the principal direction are called the first entry site and the first exit site. Using these two sites, other sites will be labeled entry and exit sites (see Sect. 4.2).

From the preceding discussion the set of sites which makes the 1ST, is built step by step. Starting from a set with the central site, the first step adds the nearest neighbours of the central site. The following procedure

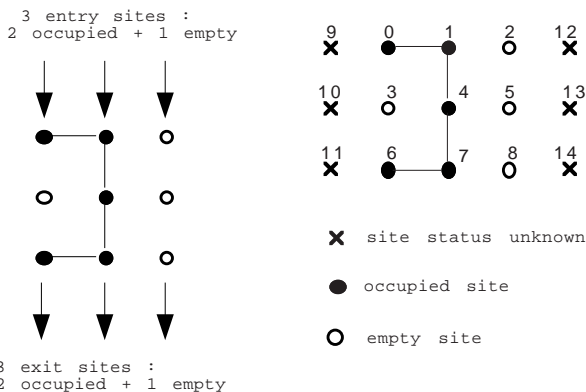

Fig. 1. The 1-site sensitive tile for the square lattice in 2 dimensions.

is performed.

- A path is searched within the set such that it contains the first entry, the central site, the first exit and a closed path.
- If the such a closed path exists then the set of sites and bonds is the 1ST and the procedure is stopped.
- Else, the next nearest neighbours of the central site are added and the procedure is repeated.

The principal directions are grouped into families according to the lattice symmetries. In Figure 1, the two diagonal directions form one family, while the horizontal and vertical directions form another family. Each principal direction in a family produces the same 1ST, leading to the same $R(p)$ and p_c . The principal directions in the same family are said to be equivalent directions. The 1ST is often different for principal directions in different families. The values of p_c are also often different.

Given one direction in the family, the other equivalent directions are called transversal directions.

A “sensitive” site is the central site of a 1ST. The 1ST transforms a “pivotal” site into a “sensitive” site for a given axe of symmetry.

The 1-site sensitive tile (1ST) is not the minimal tile of crystallography. It does not necessarily allow to pave all the embedding space; it allows to pave a slice of the embedding space along the principal direction.

Along the principal direction, one can map all the lattice vertices and all the bonds on a slice of the lattice parallel to the principal direction. When repeating the tile, some sites and bonds are allowed to be mapped twice. This double mapping occurs only at the entry and exit sites.

3.2 Definition of the “entry” and “exit” sites

The labeling of sites within the 1ST, as entry or exit sites is constructed as follows.

Given the central site of the 1ST, the first pair of entry/exit sites is obtained by taking its 2 nearest sites along the principal direction: one on each side.

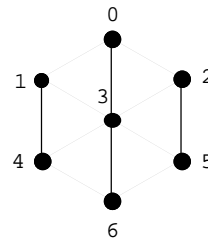

Fig. 2. The 1ST for the triangular lattice in 2 dimensions.

Taking the hyperplane orthogonal to the principal direction which contains the first entry (resp. exit) site, the entry (resp. exit) sites are defined as the largest set of sites in this hyperplane such that the first entry (resp. exit) site is the barycenter with equal weights of the set. The two sets, entry and exit sites, are then further restricted by the constraint that the crossing of the lattice by a walker has to be forward/backward symmetric. It follows from this definition that the entry and exit sets of sites are exchanged by reversal of the principal direction. Therefore if one of the sets is larger than the other one, some of its sites are removed and the number of entry sites is always equal to the number of exit sites.

The entry of the lattice by a walker should not privilege any direction around the principal direction. The principal direction is the only symmetry when crossing the lattice.

For instance, in the square lattice in two dimensions drawn in Figure 1, the first entry (resp. exit) site is labeled 1 (resp. 7). The entry hyperplane is the straight line passing by 9, 0, 1, 2, 12 and the largest set of sites, within the 1ST, which has site 1 as barycenter with equal weights is $\{0, 2\}$. Hence the entry sites are $\{0, 1, 2\}$. The principal direction passing by the central site 4 is the straight line passing by 1, 4, 7. The exit hyperplane is the straight line passing by 11, 6, 7, 8, 14 and the largest set of sites, in the 1ST, which has 7 as barycenter with equal weights is $\{6, 8\}$. Hence the exit sites are $\{6, 8\}$.

In the triangular lattice in two dimensions drawn in Figure 2, the first entry (resp. exit) site is labeled 0 (resp. 6). The principal direction passing by the central site 3 is the straight line passing by 0, 3, 6. There is no site in the hyperplane orthogonal to this line and passing by the site 0 except 0 itself, hence site 0 is the only entry site.

In the honeycomb lattice in two dimensions drawn in Figure 8, the central site is labeled 6, the principal direction passing by the central site is the straight line which contains 0, 6, 11. The first entry and exit sites are 0 and 11. In the hyperplane orthogonal to the principal direction and passing by the site 0 there is only the site 2, hence 0 is not the barycenter with equal weights of the set $\{2\}$. Therefore site 2 is not an entry site.

In the honeycomb lattice in two dimensions drawn in Figure 9, the central site is labeled 7, the principal direction (of this family) passing by the central site is the straight line which contains 0, 7, 11. The first entry and exit sites are 0 and 11. In the hyperplane orthogonal to

the principal direction and passing by the site 0 there are 2 sites, $\{3, 4\}$ but on the hyperplane passing by the site 11 there is no other site. Therefore the sites 3 and 4 are not entry sites.

3.3 Definition of the “configurations and paths”

A configuration is given by the states (occupied, empty) of all the sites in the 1ST. If the 1ST contains k sites, there are 2^k configurations. Of these 2^k configurations, only a fraction are considered for the computation of p_c . A configuration is an allowed configuration if it meets two conditions described below. Let's define a path in the configuration. A path is a sequence of bonds joining neighbouring occupied sites, starting from an occupied entry site and ending in an occupied exit site. The first condition for accepting a configuration is the existence of a path in this configuration. The second condition is that there is no path when the central site is empty. This condition is a consequence of our requirement that the change of the central site from empty to occupied creates a crossing path through the lattice from two disconnected clusters. These two conditions are enough to define the list of configurations contributing to $R(p)$.

A surface site is a site which is not an entry or an exit site and which connects the 1ST to the rest of the lattice.

A surface path is a path which connects an entry to an exit without containing the central site: these paths often use surface sites to avoid the central site. With the above definition the surface paths are excluded from the list of allowed configurations.

The existence of equivalent directions may break the directionality. When the central site is set empty, the configurations which have a closed loop connect the walker from the principal direction to another equivalent direction.

To prevent this case, first a loop path is defined as being: a closed path, and a path which contains the central site.

Then the following rule is enforced. If:

- a site s in the lattice, is not in the 1ST but is the neighbour of a 1ST surface sites,
- the 1ST surface site is in a loop path,
- the 1ST surface site is on a transversal direction of the principal direction.

Then the status of site s is set to empty.

The 1ST being the smallest set of points in the sense of Section 4.1, the closed paths in two dimensions are also often loop paths, but this is specific to lattices embedded in 2 dimensions. For instance, in the cubic lattice in 3 dimensions, each surface site has three (corner) or four neighbouring surface sites which can be in a closed path not containing the central site.

From the rules defined above, it follows that the configurations around a pivotal site are not all allowed. A sensitive site has a more restrictive definition than a pivotal site: the former is associated to a specific symmetry while the second one is not.

3.4 The probabilities of the configurations and computation of p_c

The 1ST list of configurations contains all the paths allowing (resp. forbidding) the walker to cross the 1ST when the central site is occupied (resp. empty). The list of all these configurations associated to a principal direction is called the 1ST list of configurations. The probability associated to this 1ST list is a polynomial $R(p)$ representing the probability of crossing the tile along its associated principal direction. The maximum of this polynomial in the interval $]0, 1[$ is the computed value of p_c .

Due to the lattice symmetry, directions in the same family of principal directions lead to the same polynomial. The number of families depends on the lattice symmetries. When there is only one family, as in the triangular lattice, the value of p_c computed by this method is equal to the exact value.

The value computed by Monte Carlo methods is not related to a peculiar direction, hence it will be called the non directional value of p_c . In the case of several families, there are several values of p_c , all larger than the non directional value of p_c .

After listing all possible configurations which follow the above rules, there are three types of configurations:

- the configurations with no surface site,
- the configurations with no surface site in a loop path,
- the configurations with surface sites within a loop path.

Hence a configuration can have a occupied sites, in the 1ST, b empty sites in the 1ST and c empty sites among the neighbouring sites of the 1ST. The case $c = 0$ corresponds to the two former configuration types.

For all three types, the probability of a configuration is given by:

$$p^a (1 - p)^{b+c}.$$

Having listed and computed the polynomials associated to each configuration, the sum of all these polynomials gives the polynomial $R(p)$ associated to the 1ST list of configurations.

The computation of the maximum value of this polynomial in the interval $]0, 1[$ is the last step of the computation and gives the value of p_c .

4 Example of computations

The computation of the values of p_c for all the families of principal directions is given for four lattices in two dimensions for which the non directional value of p_c is known by other methods: square, triangular, honeycomb and kagome.

The sites labeling used in this section is the same as the one used in programs which search all the allowed configurations for a given 1ST and its associated principal direction. The programs (written in Java) and the examples are available at <http://home.cern.ch/~rosowsky>.

Table 1. The 1ST of the square lattice type A.

entry	exit	surface sites	surface paths
0, 1, 2	6, 7, 8	3, 5	(0, 3, 6); (2, 5, 8)

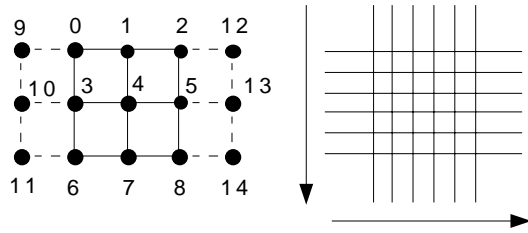
Fig. 3. Square lattice in two dimensions: type A.

4.1 Square lattice in two dimensions

The square lattice in two dimensions has two families of principal directions that will be noted type A and type B.

The 1ST and the family of principal directions of type A are drawn in Figure 3. The principal directions are given by the arrows, and the sites are labeled from 0 to 14. The 1ST is made of the sites labeled 0 to 8:

$$1ST = [0, 1, 2, 3, 4, 5, 6, 7, 8].$$

The sites labeled 9 to 14 are neighbouring sites not in the 1ST. Table 1 gives the sites' labels for the entry, exit, surface sites and surface paths. The loop paths are: (0, 1, 4, 3), (1, 2, 5, 4), (3, 4, 6, 7) and (4, 5, 7, 8). When the surface site 3 is in a loop path, the neighbouring site 10 is set to the status empty. When the surface site 5 is part of a loop path, the neighbouring site 13 is set to the status empty.

There are 77 configurations drawn in the Appendix and the probability of this set of configurations is given by:

$$R(p) = p^3 + 4p^4 - 6p^5 - 12p^6 + 14p^7 + 6p^8 - 3p^9 - 8p^{10} + 4p^{11}.$$

This polynomial has a single maximum in the interval $]0, 1[$ which is the value of the percolation threshold along the family of principal direction type A:

$$p_c = 0.5928716.$$

Being a root of the polynomial $R'(p)$, a computer program like Maple or Mathematica can compute the value of p_c with arbitrary precision. The result is given here with 7 digits to have the same precision as the non directional percolation value [16] which is equal to:

$$p_c = 0.5927460.$$

The 1ST and the family of principal directions of type B are drawn in Figure 5. The principal directions are given by the arrows, and the sites are labeled from 0 to 16. The 1ST is made of the sites labeled 0 to 8:

$$1ST = [0, 1, 2, 3, 4, 5, 6, 7, 8].$$

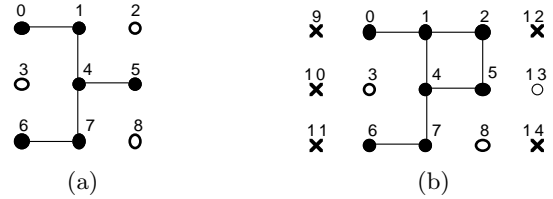
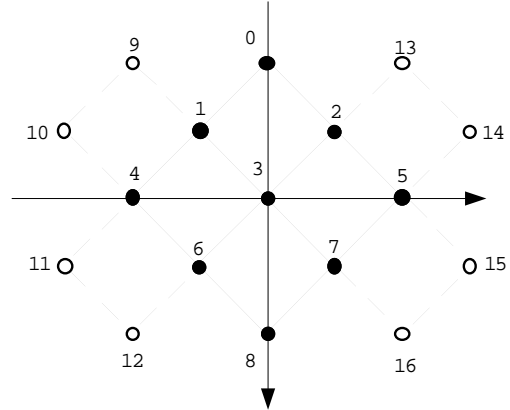

Fig. 4. Example of surface site and loop path: (a) site 5 is an occupied surface site which can connect the configuration to the lattice in a transversal direction; (b) sites (1, 4, 5, 2) form a loop path with an occupied surface site 5 in the transversal direction.

Fig. 5. Square lattice in two dimensions: type B.

Table 2. The 1ST of the square lattice type B.

entry	exit	surface sites	surface paths
0	8	1, 2, 4, 5, 6, 7	(0, 1, 2, 3); (1, 3, 4, 6); (2, 3, 5, 7) and (3, 6, 7, 8)

The sites labeled 9 to 16 are neighbouring sites not in the 1ST. Table 2 gives the sites' labels for the entry, exit, surface sites and surface paths. The loop paths are: (0, 1, 2, 3), (1, 3, 4, 6), (2, 3, 5, 7) and (3, 6, 7, 8).

The loop paths and the corresponding neighbouring site which have to be set empty are the following:

- (0, 1, 2, 3) \rightarrow 9, 13,
- (1, 3, 4, 6) \rightarrow 9, 10, 11, 12,
- (2, 3, 5, 7) \rightarrow 13, 14, 15, 16,
- (3, 6, 7, 8) \rightarrow 12, 16.

The loop path above are allowed, but not simultaneously because they would imply a surface path. More precisely, (0, 1, 2, 3), (1, 3, 4, 6), (3, 6, 7, 8) are not allowed simultaneously. For the same reason (0, 1, 2, 3), (2, 3, 5, 7), (3, 6, 7, 8) are not allowed simultaneously.

There are 21 configurations and the probability of this set of configurations is given by:

$$R(p) = 4p^5 - 6p^6 + p^7 + p^9.$$

This polynomial has a single maximum in the interval $]0, 1[$ which is equal to:

$$p_c = 0.7305222.$$

Table 3. The 1ST of the triangle lattice.

entry	exit	surface sites	surface paths
0	6	1, 2, 4, 5	(0, 1, 4, 6); (0, 2, 5, 6)

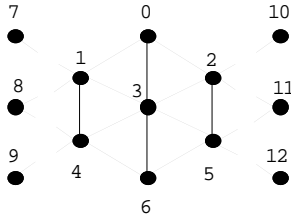
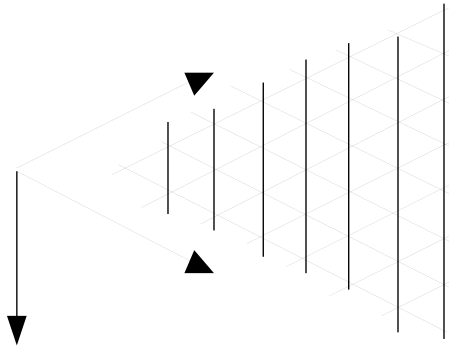
**Fig. 6.** Triangle lattice in two dimensions: site labeling.**Fig. 7.** Triangle lattice in two dimensions: all principal directions are equivalent.

4.2 Triangular lattice in two dimensions

The triangular lattice in two dimensions has only one family of principal directions. It is one of the very few cases where the percolation threshold was found without the help of a computer [6].

The 1ST and the family of principal directions are drawn in Figures 6 and 7. The principal directions are given by the arrows, and the sites are labeled from 0 to 12. The 1ST is made of the sites labeled 0 to 6: $1ST = [0, 1, 2, 3, 4, 5, 6]$.

The sites labeled 7 to 12 are neighbouring sites not in the 1ST. Table 3 gives the sites' labels for the entry, exit, surface sites and surface paths.

The following loop paths are forbidden because their existence implies a surface path:

- (1, 3, 4),
- (2, 3, 5).

The allowed loop paths and the corresponding neighbouring site which have to be set empty are the following:

- (0, 2, 3) \rightarrow 10 and 11,
- (3, 5, 6) \rightarrow 11 and 12,
- (0, 1, 3) \rightarrow 7 and 8,
- (3, 4, 6) \rightarrow 8 and 9.

Table 4. The 1ST of the honeycomb lattice type A.

entry	exit	surface sites	surface paths
0	11	1, 2, 4, 5, 7, 10, 12	(0, 3, 1, 4, 7, 9, 11) (0, 2, 5, 8, 10, 12, 11)

The loop path above are allowed but some combinations are forbidden because they would create a surface path:

- (0, 2, 3) and (3, 5, 6),
- (0, 1, 3) and (3, 4, 6).

There are 9 configurations and the probability of this set of configurations is given by:

$$R(p) = p^3 - 6p^5 + 4p^6 + 9p^7 - 12p^8 + 4p^9.$$

This polynomial has a single maximum in the interval $]0, 1[$ which is equal to:

$$p_c = 0.5.$$

Since the triangular lattice has a single family of principal direction, this value is also the non directional value of p_c that one find with other methods.

4.3 Honeycomb lattice in two dimensions

The honeycomb lattice in two dimensions has two families of principal directions that will be noted type A and type B.

The 1ST and the family of principal directions of type A are drawn in Figure 8. The principal direction is given by the arrow (0 \rightarrow 11), and the sites are labeled from 0 to 18. The 1ST is made of the sites labeled 0 to 12:

$$1ST = [0, 1, 2, 3, 4, 5, 6, 7, 8, 9, 10, 11, 12].$$

The sites labeled 13 to 18 are neighbouring sites not in the 1ST. Table 4 gives the sites' labels for the entry, exit, surface sites and surface paths.

The loop paths and the corresponding neighbouring site which have to be set empty are the following:

- (0, 2, 5, 8, 6, 3) \rightarrow 15,
- (1, 3, 6, 9, 7, 4) \rightarrow 16, 18
- (6, 8, 10, 12, 11, 9) \rightarrow 13, 14.

The loop paths above are allowed, but not simultaneously because they would imply a surface path.

One shall note that the sites 2, 4 and 12 have neighbouring sites which are not in the 1ST and which are not taken into account because these sites are not located on an equivalent principal direction.

There are 192 configurations and the probability of this set of configurations is given by:

$$R(p) = p^5 - 4p^6 + 16p^7 - 28p^8 + 29p^9 - 30p^{10} + 19p^{11} - p^{12} - 3p^{14} + p^{15}.$$

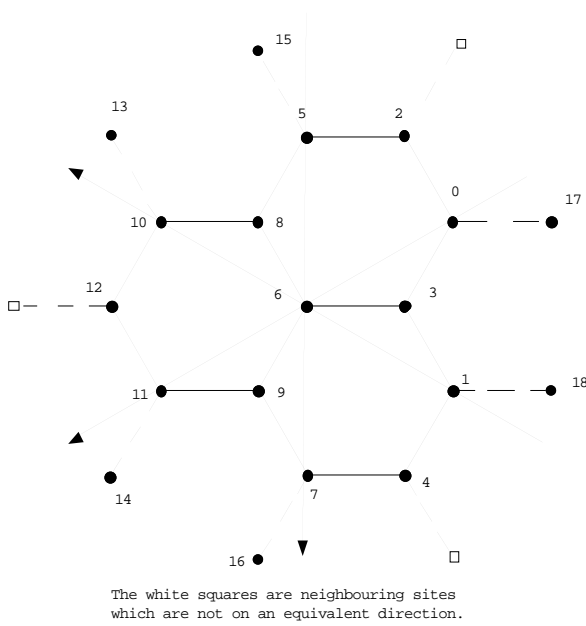

Fig. 8. Honeycomb lattice type A: site labeling and principal direction.

This polynomial has a single maximum in the interval $]0, 1[$ which is the value of the percolation threshold along this principal direction type A:

$$p_c = 0.765\ 069.$$

The result is given here with six digits to have the same precision as the non directional percolation value [12,20] which is equal to:

$$p_c = 0.697\ 043.$$

The 1ST and the family of principal directions of type B are drawn in Figure 9. The principal direction is given by the arrow ($0 \rightarrow 11$). The 1ST is made of the sites labeled 0 to 12:

$$1ST = [0, 1, 2, 3, 4, 5, 6, 7, 8, 9, 10, 11, 12].$$

The sites labeled 13 and 14 are neighbouring sites not in the 1ST. Table 5 gives the sites' labels for the entry, exit, surface sites and surface paths.

The loop paths and the corresponding neighbouring site which have to be set empty are the following:

- $(0, 1, 3, 5, 6, 7) \rightarrow 13,$
- $(0, 2, 4, 9, 8, 7) \rightarrow 14$
- $(6, 10, 11, 12, 8, 7) \rightarrow$ no site on an equivalent direction.

The loop paths above are allowed, but not simultaneously because they would imply the surface path. One shall note that the sites 1, 2, 5, 9, 10 and 12 have neighbouring sites which are not in the 1ST and which are not taken into account because these sites are not located on an equivalent principal direction.

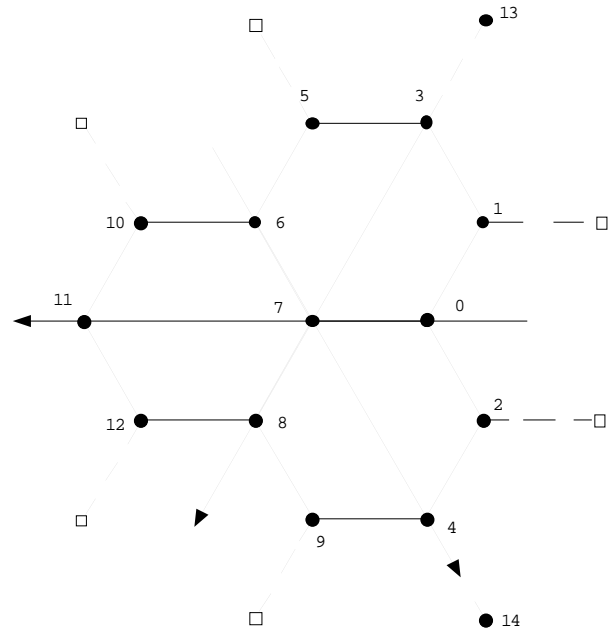

Fig. 9. Honeycomb lattice type B: site labeling and principal direction.

Table 5. The 1ST of the honeycomb lattice type B.

entry	exit	surface sites	surface paths
0	11	1, 2, 3, 4, 5, 7, 8, 9, 10, 12	$(0, 2, 4, 9, 8, 12, 11)$ $(0, 1, 3, 5, 6, 10, 11)$

There are 237 configurations and the probability of this set of configurations is given by:

$$R(p) = 2p^5 - 9p^6 + 28p^7 - 40p^8 + 30p^9 - 19p^{10} + 7p^{11} + 3p^{13} - 2p^{14}.$$

This polynomial has a single maximum in the interval $]0, 1[$ which is the value of the percolation threshold along this principal direction type B:

$$p_c = 0.782\ 576.$$

4.4 Kagome lattice in two dimensions

The kagome lattice, is (with the triangular case) one of the very few cases where the percolation threshold was found without the help of a computer [6]. The kagome lattice in two dimensions has two families of principal directions that will be noted type A and type B.

The 1ST and the principal direction of type A are drawn in Figure 10. The principal direction is given by the arrow ($0 \rightarrow 4$), and the sites are labeled from 0 to 6. The 1ST is made of the sites labeled 0 to 4:

$$1ST = [0, 1, 2, 3, 4].$$

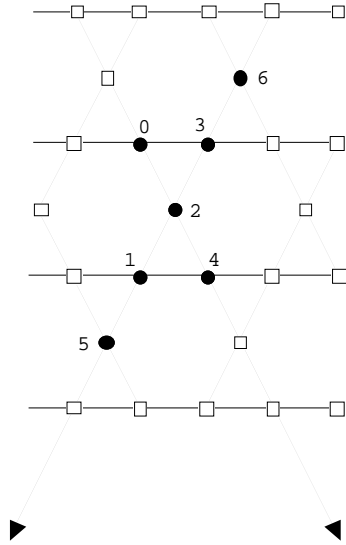

Fig. 10. Kagome type A: site labeling and principal direction.

Table 6. The 1ST of the kagome lattice type A.

entry	exit	surface sites	surface paths
0	4	1, 3	none

Table 7. The 1ST of the kagome lattice type B.

entry	exit	surface sites
0	24	1, 2, 3, 4, 5, 10 14, 19, 20, 21, 22, 23

The sites labeled 5 and 6 are neighbouring sites not in the 1ST. Table 6 gives the sites' labels for the entry, exit, surface sites and surface paths.

The loop paths and the corresponding neighbouring site which have to be set empty are the following:

- (0, 2, 3) → 6,
- (1, 2, 4) → 5.

There are 4 configurations and the probability of this set of configurations is given by:

$$R(p) = p^3 - 2p^5 + p^7.$$

This polynomial has a single maximum in the interval]0, 1[which is the value of the percolation threshold along this principal direction type A:

$$p_c = 0.654\ 653\ 7.$$

This result is to be compared with the non directional percolation value which is equal to:

$$p_c = 0.652\ 703\ 6.$$

The 1ST and the principal direction of type B are drawn in Figure 11. Table 7 gives the sites' labels for

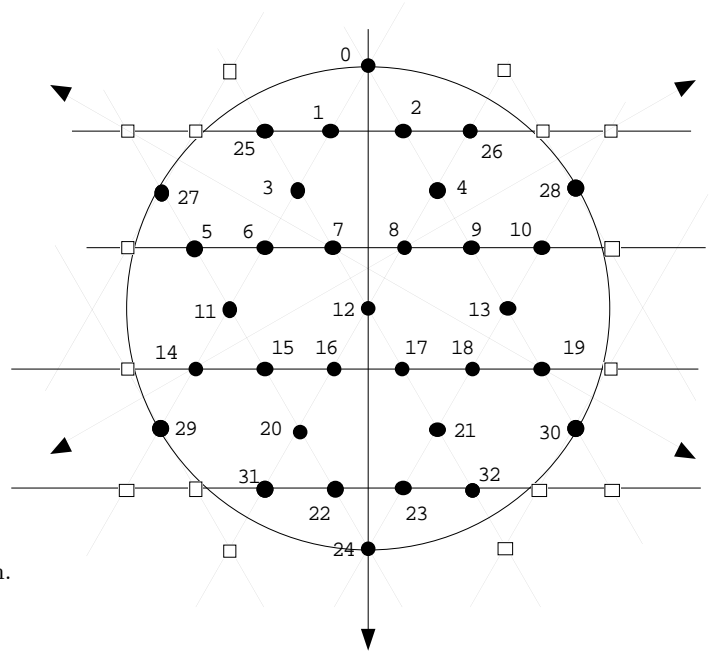

Fig. 11. Kagome type B: site labeling and principal direction.

the entry, exit and surface sites. The principal direction is given by the single arrow (0 → 32). The two nearest site of the central site on the principal direction are the first entry and first exit site. The radius of the smallest disc which contains enough sites to build a closed path with these three sites is drawn in Figure 11. The 1ST is made of the sites labeled 0 to 32:

$$\text{1ST} = [0, 1, 2, 3, 4, 5, 6, 7, 8, 9, 10, 11, 12, 13, 14, 15, 16, 17, 18, 19, 20, 21, 22, 23, 24, 25, 26, 27, 28, 29, 30, 31, 32].$$

The double arrows show the 2 equivalent lattice axis of symmetry, since these axis do not cross at the same central site, they are not equivalent principal directions. Therefore there is no site that has to be set to empty when there is a loop path.

The number of paths allowed is very large but they all contain one of the following twelve sets of sites:

- {0, 1, 3, 7, 12, 17, 21, 23, 24}
- {0, 1, 3, 7, 12, 16, 20, 22, 24}
- {0, 1, 3, 6, 7, 8, 11, 12, 15, 20, 22, 24}
- {0, 1, 3, 7, 8, 9, 12, 13, 18, 21, 23, 24}
- {0, 1, 3, 6, 11, 12, 15, 16, 17, 21, 23, 24}
- {0, 1, 3, 6, 11, 12, 15, 16, 17, 20, 22, 24}
- {0, 2, 4, 8, 12, 16, 20, 22, 24}
- {0, 2, 4, 8, 12, 17, 21, 23, 24}
- {0, 2, 4, 7, 8, 9, 12, 13, 18, 21, 23, 24}
- {0, 2, 4, 6, 7, 8, 11, 12, 15, 20, 22, 24}
- {0, 2, 4, 9, 12, 13, 16, 17, 18, 20, 22, 24}
- {0, 2, 4, 9, 12, 13, 16, 17, 18, 21, 23, 24}.

These twelve sets contain only 21 sites and only these 21 sites have to be considered to find the 1ST list of configurations. To build a path, one first selects one of

Table 8. The signature paths which are contained in the surface paths.

signature paths
(0, 1, 3, 6, 11, 15, 20, 22, 24)
(0, 2, 4, 9, 13, 18, 21, 23, 24)
(0, 1, 3, 6, 7, 8, 9, 13, 18, 17, 16, 15, 20, 22, 24)
(0, 2, 4, 9, 8, 7, 6, 11, 15, 16, 17, 18, 21, 23, 24)
(0, 1, 3, 6, 7, 8, 9, 13, 18, 21, 23, 24)
(0, 2, 4, 9, 8, 7, 6, 11, 15, 20, 22, 24)
(0, 1, 3, 6, 11, 15, 16, 17, 18, 21, 23, 24)
(0, 2, 4, 9, 13, 18, 17, 16, 15, 20, 22, 24)

these sets and check that it does not give a surface path. Then, all the combinations of empty, occupied sites taken among the remaining 12 sites can complement the set to give a configuration. This is a consequence from the fact that there is not site out the 1ST that must be set to empty when there is a loop path. There are 4096 such combinations and these 4096 combinations do not contribute to $R(p)$ because they factorise and give:

$$(p + (1 - p))^{12} = 1.$$

Hence the total number of configurations is $2^{33} = 8\,589\,934\,592$ but the number of configurations to be explored is $2^{21} = 2\,097\,152$.

The number of surface paths is very large but they all contain one of the eight paths listed in Table 8. These eight paths are used as signature for the surface path in a configuration, hence they allow to exclude the forbidden paths. These signature paths do not contain exclusively surface sites.

There are 197 448 allowed configurations and the probability of this set of configurations is given by:

$$R(p) = 4p^9 - 4p^{12} - 8p^{13} - 6p^{14} + 9p^{15} + p^{16} + 14p^{17} + 10p^{18} - 19p^{19} - 16p^{20} + 18p^{21} - 3p^{22}.$$

This polynomial has a single maximum in the interval $]0, 1[$ which is the value of the percolation threshold along this principal direction type B:

$$p_c = 0.805\,561.$$

5 Possible extensions and conclusion

Having computed all the values of p_c for percolation along the principal directions, it should be possible, in principle, to combine them to get the non directional value of p_c . At the moment the procedure to make this combination is not known.

Another interesting aspect under study is to extend the method to other tiling of the plane: the Penrose tiling, and the polyominoes [3, 42].

A physical conclusion is suggested by the percolation case: the lack of a specific scale at the critical point is often misinterpreted as a loss of information about this point. The method presented in this paper shows, for the case of percolation on regular lattices, that the opposite is true: the lack of a specific scale at the critical point means that the information at all scales is contained locally and at any scale. In other words, a mathematical object (here a polynomial) can be built to extract the value of the critical point from a finite set of configurations.

I thank J.-F. Renardy for reviewing this article and for its helpful comments to improve the manuscript. I am grateful to M. Spiro, director of the DSM/DAPNIA-SPP at the Commissariat à l'Énergie Atomique for supporting this study.

Appendix A

The 77 configurations of the square lattice type A in 2 dimensions.

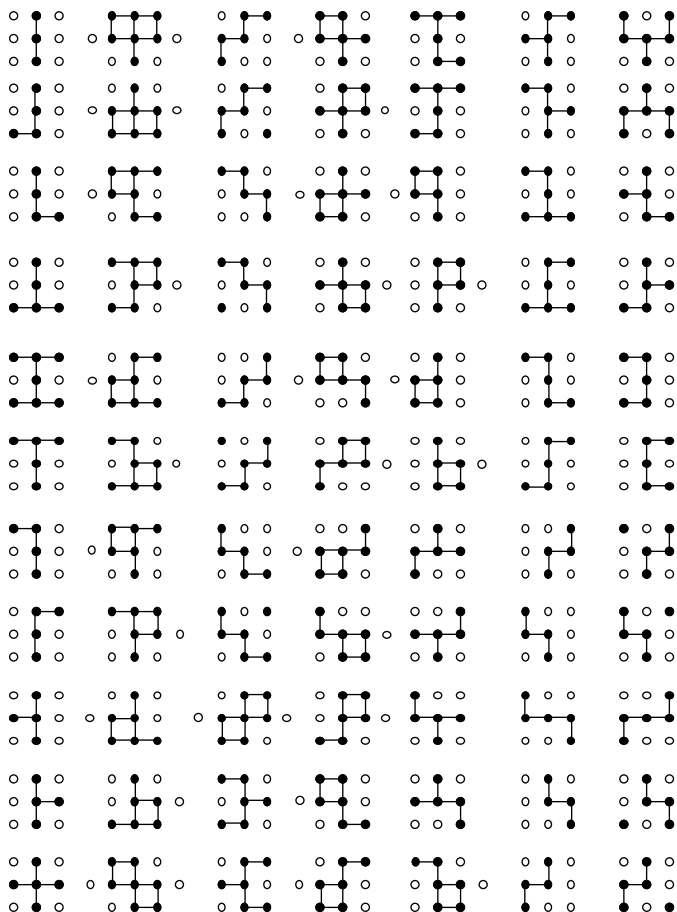

References

1. D. Stauffer, A. Aharony, *Introduction to Percolation Theory*, Revised 2nd edn. (Taylor and Francis, London, 1994).
2. A.L. Barabasi, H.E. Stanley, *Fractal Concepts In Surface Growth* (Cambridge Univ. Press, Cambridge, 1995).
3. S.W. Golomb, *Polyominoes: Puzzles, Patterns, Problems, and Packings*, Revised edn. (Princeton Univ. Press, Princeton, 1994).
4. S.R. Broadbent, *J. R. Stat. Soc. B* **16**, 68 (1954).
5. S.R. Broadbent, J.M. Hammersley, *Proc. Camb. Philos. Soc.* **53**, 629 (1957).
6. J.W. Essam, M.F. Sykes, *J. Math. Phys. (N.Y.)* **5**, 1117 (1964).
7. C.M. Fortuin, P.W. Kasteleyn, *Physica* **57**, 536 (1971).
8. J. Hoshen, R. Kopelman, *Phys. Rev. B* **14**, 3438 (1976).
9. J.C. Wierman, *J. Phys. A* **17**, 1525 (1984).
10. R.M. Ziff, *Phys. Rev. Lett.* **56**, 545 (1986).
11. J.C. Wierman, *J. Phys. A* **21**, 1487 (1988).
12. C. Dussert, G. Rasigni, M. Rasigni, *Phys. Lett. A* **139**, 35 (1989).
13. F. Yonezawa, S. Sakamoto, Motoo Hori, *Phys. Rev. B* **40**, 636 (1989).
14. F. Yonezawa, S. Sakamoto, Motoo Hori, *Phys. Rev. B* **40**, 650 (1989).
15. J.L. Cardy, *J. Phys. A* **25**, L201 (1992).
16. R.M. Ziff, *Phys. Rev. Lett.* **69**, 2670 (1992).
17. R.P. Langlands, C. Pichet, Ph. Pouliot, Y. Saint-Aubin, *J. Stat. Phys.* **67**, 553 (1992).
18. S. Galam, A. Mauger, *J. Appl. Phys.* **75**, 5526 (1994).
19. S. Galam, A. Mauger, *Physica A* **205**, 502 (1994).
20. C. d'Iribarne, G. Rasigni, M. Rasigni, *Phys. Lett. A* **209**, 95 (1995).
21. I. Jensen, A.J. Gutmann, *J. Phys. A* **28**, 4813 (1995).
22. S. Galam, A. Mauger, *Phys. Rev. E* **53**, 2177 (1996).
23. S. Galam, A. Mauger, *Phys. Rev. E* **55**, 1230 (1997).
24. S.C. van der Marck, *Phys. Rev. E* **55**, 1228 (1997).
25. S.C. van der Marck, *Phys. Rev. E* **55**, 1514 (1997).
26. S. Galam, A. Mauger, *Phys. Rev. E* **56**, 322 (1997).
27. M. Aizenman, *Nucl. Phys. B* **485**, 551 (1997).
28. R.M. Ziff, S.R. Finch, V.S. Adamchik, *Phys. Rev. Lett.* **79**, 3447 (1997).
29. S. Galam, A. Mauger, *Eur. Phys. J. B* **1**, 255 (1998).
30. S.C. van der Marck, *Int. J. Mod. Phys. C* **9**, 529 (1998).
31. P. Kleban, R.M. Ziff, *Phys. Rev. B* **57**, R8075 (1998).
32. M. Acharyya, D. Stauffer, *Int. J. Mod. Phys. C* **9**, 643 (1998).
33. J.L. Cardy, *J. Phys. A* **31**, L105 (1998).
34. Chai-Yu Lin, Chin-Kun Hu, Jau-Ann Chen, *J. Phys. A* **31**, L111 (1998).
35. H.K. Janssen, K. Oerding, F. van Wijland, H.J. Hilhorst, *Eur. Phys. J. B* **7**, 137 (1999).
36. A. Bunde, J.W. Kantelhardt, L. Schweitzer, *Phys. Rev. Lett.* **22**, 4907 (1998); J.W. Kantelhardt, A. Bunde, L. Schweitzer, *Phys. Rev. Lett.* **81**, 4907 (1998).
37. R.M. Ziff, C.D. Lorentz, P. Kleban, *Physica A* **266**, 17 (1999).
38. P.N. Suding, R.M. Ziff, *Phys. Rev. E* **60**, 275 (1999).
39. A. Bunde, S. Havlin, M. Porto, *Distribution of Dangling Ends on the Incipient Percolation Cluster, 210th WE-Heraeus Seminar on Percolation, Interaction, Simulations of Transport in Disordered Systems, PILS'98 Berlin, Germany; 6 - 9 Oct 1998, Proceedings M Schreiber*, *Ann. Phys. (Leipzig)* **8**, 5 (1998).
40. A. Bunde, S. Havlin, M. Porto, H.E. Roman, *Phys. Rev. E* **58**, 5205 (1998).
41. J. Tobochnik, *Phys. Rev. E*, 5205 (1999).
42. C Moore, *Some Polyomono Tilings of the Plane, Santa Fe Institute (1999)*. Preprint cond-mat/99-04-032 at <http://xxx.lanl.gov>.
43. L.N. Shchur, *12th Workshop on Computer Simulation Studies in Condensed Matter Physics Athens, GA, USA; Proceedings D.P. Landau et al.* (Springer, Berlin, 1999).
44. Y.Y. Tarasevich, S.C. van der Marck, *Int. J. Mod. Phys. C* **10**, 1193 (1999).
45. Y. Lee, J.S. Andrade Jr., S.V. Buldyrev, N.V. Dokholyan, S. Havlin, P.R. King, G. Paul, H.E. Stanley, *Phys. Rev. E* **60**, 3425 (1999).
46. J.J. Normand, H.J. Herrmann, *Int. J. Mod. Phys. C* **6**, 813 (1995).
47. J.J. Normand, H.J. Herrmann, *Int. J. Mod. Phys. C* **1**, 207 (1990).
48. J.J. Normand, H.J. Herrmann, *J. Comp. Phys.* **64**, 380 (1986).
49. S.C. van der Marck, *Int. J. Mod. Phys. C* **9**, 529 (1998).